

CT6038-GU24

Line Voltage 120V
Front Loaded Gimbal

Catalog Number: _____

Type _____

Project: _____



CT6038-GU24

Description

Compact adjustable accent lights for a wide range of beamspreads in line voltage lamps. Yoke permanently adjusts to position lamp in any direction. Designed for use on either circuit of Capri combination one or two circuit track. GU24 socket is ideal for conformance to energy codes with lighting power density (w/ft^2) restrictions. See "listing" specification below for lamp compatibility.

Features

- Low profile construction, only slightly larger than the lamp itself.
- Rotate and lock retaining ring provides lamp support from below.
- Adjustable yoke permits aiming in any direction.
- Nylon scratch guard.
- Captive lamp sockets.
- Integral switch on track plug housing permits interruption of power for routine lamp maintenance.
- Socket enclosure supported for ease of lamp maintenance without handling electrical contacts.
- High efficacy GU24 rotate-and-lock socket.

CATALOG SYSTEM AND OPTIONS

SAMPLE CATALOG NUMBER: CT6038W-GU24

Track Head	Finishes	Base
CT6038	W White BK Black SL Silver	GU24 GU24 Socket

This product may be covered by one or more of the following U.S. Patents: #4,822,292, #4,931,917, #5,325,281. Other U.S. or Foreign Patents may apply. UL pending.

SPECIFICATIONS

- Gimbal Ring** - Powder painted die-formed steel. Rotate and lock lamp retaining ring can be installed from below without the use of tools.
- Yoke** - Die-formed steel rotates 358° horizontally and swivels 90° vertically, permitting aiming in any direction, from horizontal to vertical. Permanent tension swivel maintains setting after adjustment.
- Socket Enclosure** - Die-stamped, finished to match gimbal ring. Porcelain, medium base socket, with nickel plated copper screw shell.

4. **Finishes** - Choice of painted finishes W (white) or BK (black) or SL (silver).

5. **GU24 Base** - For use with 14W PAR38 LED

6. **Listing** - ETL listed for use with Cree LRP-38 GU24 PAR38 LED lamp series (not provided by Philips Capri).

DIMENSIONS

Catalog #	Dimensions		
	A	B	C
CT6038-GU24	5 1/4" (133 mm)	6 1/4" (143 mm)	10 1/4" (260 mm)

Legend
Diameter: A
Length: B
Max. Extension: C

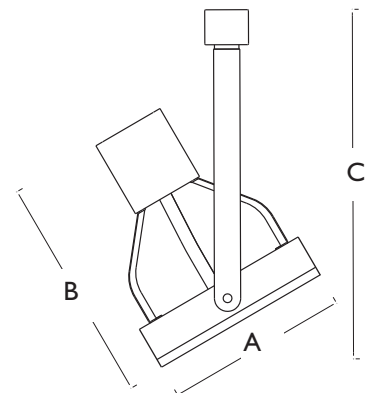

REV. 2/12

