

## Architectural Downlighting

### OM6LED 1500/2000 6" LED 1500/2000 Lumen Wall Wash



#### Specifier's Reference

Project
Type
Model No.
Comments

#### application

- Philips Omega Revelation LED combines MesoOptics® diffusion with the proprietary remote phosphor technology to produce one of the most efficient and advanced LED systems available for general illumination.

#### light engine

- Philips Omega mixing chamber/optical assembly: Remote phosphor technology provides increased efficiency and color stability by redirecting back reflected light. Phosphor lens assembly converts high brightness blue light into white light for an even, diffused pattern, eliminating bright spots often created by individual LEDs. This technology provides consistent, stable color with CCT color control of +/- 100K over the life of the light engine and provides 20% higher efficiency.
- LED Array: The LED Array consists of a metal core circuit board with 22 high brightness royal blue LEDs.
- Color: Available in three CCT options, 3000K, 3500K or 4000K with 80CRI +/-2%.
- Electrical: The power supply/driver features Advance Intelli-volt 120-277VAC 50/60Hz, with 0-10V analog dimming capability. The power supply is overload and short circuit protected as well as thermally regulated to prevent overheating. Sound rating A. Refer to dimming compatibility spec sheet for complete details. Driver has rated lifetime of 50,000 hours.
- Lifetime/Lumen Maintenance: 60,000 hour lifetime at 70% lumen maintenance light engine.

#### construction

- Thermal Management: A proprietary die-cast aluminum heat sink allows for easy and tool-less installation to the housing yoke. The heat sink is designed to properly maintain junction temperatures in recessed Non-IC applications to provide reliable performance over the life of the light engine. The heat sink incorporates alignment

tabs to properly position the heat sink with the housing

- and rust resistant springs to secure the heat sink and reflector.
- Housing: Precision die stamped 18ga galvanized steel mounting pan and yoke assembly. Allows for ceiling thickness up to 1-3/8". Yoke supports weight of heat sink and light engine assembly to prevent stress on finished reflector.
- Reflector: The lower trim is die-formed of 0.40 low iridescent aluminum and is self-flanged with a variety of finishes available. White flange is standard. Optional polished flange matching trim finish is available, add FF to the catalog number.
- C-Channels: Philips Omega Revelation C-Channels are included and provide vertical and horizontal adjustments. These allow for fast and adjustment free installation in T-bar ceilings with 1/2" tile. C-Channels simply snap on grid for proper alignment in 24" O.C. grid systems.
- Junction Box: 16ga galvanized steel. UL listed for 8 No. 12 AWG, 90C through branch circuit conductors. Allows inspection below ceiling.
- Service: Modular construction allows for easy maintenance of complete system below ceiling. Removing reflector provides easy access to heat sink and light engine assembly. This assembly may be removed by de-pressing the springs which attach to the yoke and then simply opening protective cover and unplugging the push in connector from the LED board.

#### listings & warranty

- ETL, cUL Listed. (Suitable for wet location applications.)
- Photometric testing performed using IESNA - LM79 procedures. LED lifetime testing performed using IESNA - LM80 procedures.
- 5 year Warranty

### Green Choice: OM6LED39120-R6LED30KWWCS

#### HOUSING

##### OM6LED

###### Family

**OM6LED**  
6 inch Housing

###### Voltage

**120** – 120 VAC  
50/60Hz  
**277** – 277 VAC  
50/60Hz  
**347** – Stepdown  
(347:120/277)

###### Wattage

**27** – 27 Input Watts  
**39** – 39 Input Watts

###### Option

**EM** – Bodine BSL17C  
Emergency Back-up<sup>1</sup>

#### LIGHT ENGINE - REFLECTOR

##### R6LED

###### Omega Reflector

**R6LED** – 6" Reflector

##### WW

###### Distribution

**WW** – Wall Wash

###### CCT

**30K** – 3000K  
**35K** – 3500K  
**40K** – 4000K

###### Reflector Finish

**CS** – Clear Specular  
**CSS** – Clear Semi-Specular  
**HZ** – Haze  
**GS** – Gold Specular  
**WT** – Wheat  
**PW** – Pewter  
**BZ** – Bronze  
**WH** – White, Paint  
**FF** – Finish Flange  
(as suffix to color)

#### Footnotes

1. Delivered lumen output ranges from 500-550lm.

#### General Notes

Lumen output varies depending on CCT and distribution, refer to specific IES files for details

#### Accessories (ordered separately)

**OMTCA6** - Thick ceiling adapter  
(specify finish to match reflector, ie. CS)

## energy data

### 1500 Lumen Package

Input Voltage	Input Current	Drive Current	Input Power	LED Power	THD %	Power Factor
120	0.25	350mA	27	23.1	10%	>0.9
277	0.11	350mA	27	23.1	10%	>0.9

### 2000 Lumen Package

Input Voltage	Input Current	Drive Current	Input Power	LED Power	THD %	Power Factor
120	0.36	350mA	39	35.4	10%	>0.9
277	0.17	520mA	39	35.4	10%	>0.9

## dimensions

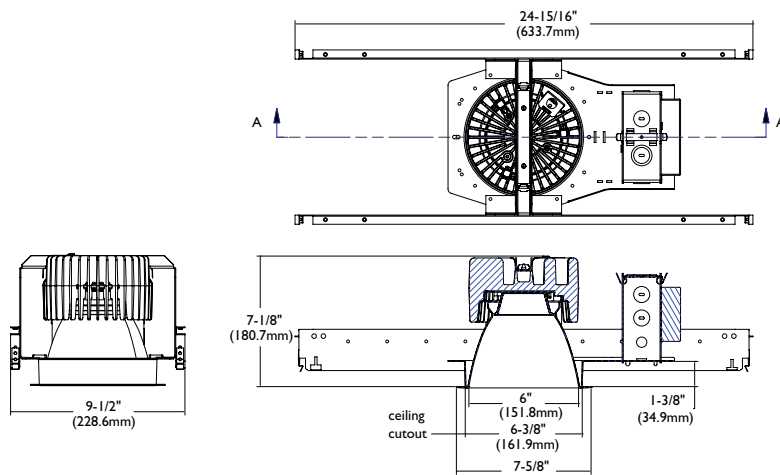

## photometrics

### OM6LED27120-R6LED40KWWCS

Tested to LM-79 standards.

#### Wall Washer with Clear Reflector

Source: (1) 22 Royal Blue LEDs

Reflectances: 80% ceiling, 50% walls, 20% floor

IES File: 28961.IES

Distance from ceiling (ft)	3' from wall, 3' on center		3' from wall, 4' on center		2'-6" from wall, 3' on center		2'-6" from wall, 2'-6" on center	
	Below Fixtures	Between Fixtures	Below Fixtures	Between Fixtures	Below Fixtures	Between Fixtures	Below Fixtures	Between Fixtures
1	4.0	4.0	4.0	4.0	5.0	5.0	5.0	5.0
2	10.0	8.0	11.0	10.0	14.0	13.0	16.0	15.0
3	12.0	10.0	14.0	13.0	17.0	14.0	19.0	17.0
4	14.0	10.0	15.0	14.0	20.0	18.0	22.0	22.0
5	15.0	13.0	17.0	17.0	21.0	21.0	24.0	23.0
6	15.0	15.0	18.0	17.0	20.0	21.0	23.0	23.0
7	14.0	15.0	18.0	18.0	19.0	18.0	22.0	20.0
8	14.0	14.0	17.0	17.0	17.0	17.0	19.0	19.0
9	13.0	13.0	16.0	16.0	8.0	15.0	16.0	17.0



©2011 Philips Omega  
All rights reserved.

776 South Green Street • Tupelo, MS 38804  
p. 800.234.1890 • f. 662.841.5501  
www.omegalighting.com  
Canadian Division  
189 Bullock Drive • Markham, Ontario L3P 1W4  
p. 905.294.9570 • f. 905.294.9811

Contact Factory for Additional Configurations.  
Specifications are subject to change without notice.



Some luminaires use fluorescent or high intensity discharge (HID) lamps that contain small amounts of mercury. Such lamps are labeled, "Contain Mercury" and/or the symbol "HG". Lamps that contain mercury must be disposed of in accordance with local requirements. Information regarding lamp recycling and disposal can be found at [www.lamprecycle.org](http://www.lamprecycle.org)