

4 or 6 Lamp
T8 or T12

APPLICATION

- Premium quality recessed static troffer for:
 - Grid inverted T (NEMA "G")
 - Flange-type for concealed mechanical suspension (NEMA "F")
 - Contact Day-Brite for other ceiling types.

CONSTRUCTION/FINISH

- Die formed ribbed and embossed steel housing.
- Housing is multi-stage phosphate treated for maximum corrosion resistance and finish coat is high reflectance baked white enamel.
- Access plate (2 K.O.'s) factory installed includes grounding screw.
- T-bar grid clips available but must be ordered separately (#GCC)

ELECTRICAL

- Class P, HPF, CBM certified ballasts comply with ©Federal Ballast Law (Public Law 100-357, 1988).
- UL listed for damp locations. C.S.A. certified optional.
- Self-contained fluorescent emergency power packs can be incorporated.

SIDE MOUNTED BALLASTS

- Reduce ballast operating temperatures (two surface contact, away from lamps).
- Increase average ballast life.
- Increase fixture efficiency.
- All lamps on the same plane for uniform lens illumination.

ENCLOSURES

- Mitered corner door frames with a choice of: Flat Aluminum, or Regressed Aluminum.
- Door frames standard with guide post spring loaded latches.
- Mechanically designed interlocks block light, no gaskets are needed.
- 3/16" nominal thickness acrylic pattern 12 lens standard (20).
- Choice of door finishes; white (standard) or black.

CATALOG NUMBER

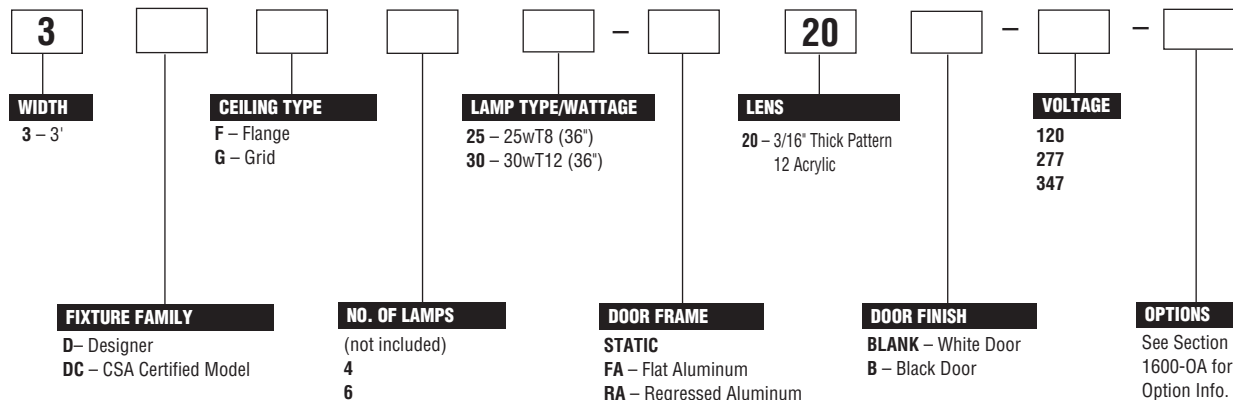

NOTES:

- With generic Electronic Ballasts (Brand selected by Day-Brite)
Suffix Catalog # with- **Ballast Quantity** - / - **EB** **Lamps Per Ballast**.

Example: -2/2-EB = Two 2 Lamp Electronic Ballasts.

Example: -2/3-EB = Two 3 Lamp Electronic Ballasts.

JOB INFORMATION

409.1-SR

3' x 3' 4 LAMP

PHILIPS
Day-Brite

DIMENSIONS

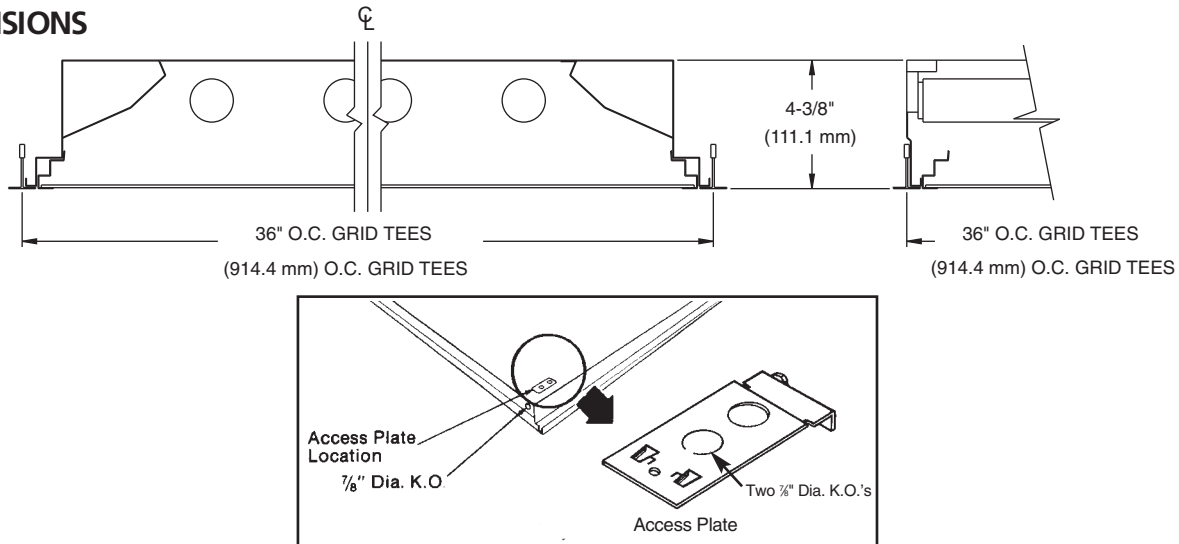

PHOTOMETRIC DATA

CATALOG # 3DG425-RA20-2/2-EB
TEST # 16158 S/MH= 1.5

LAMPS = F25 T8
BALLAST = ELECTRONIC BALLAST FACTOR = .91

LER = FL-72

COMPARATIVE YEARLY LIGHTING ENERGY COST PER 1000 LUMENS = \$3.33 BASED ON 3000 HRS. AND \$.08 PER KWH.

FIXTURE EFFICIENCY= 79.8%

CANDLEPOWER			
Angle	End	45	Cross
0	2743	2743	2743
5	2738	2730	2738
10	2701	2707	2729
15	2642	2671	2716
20	2557	2619	2698
25	2442	2562	2676
30	2303	2486	2645
35	2131	2375	2610
40	1911	2229	2547
45	1590	1915	2246
50	1159	1219	1593
55	831	851	1060
60	556	689	676
65	372	458	434
70	357	308	383
75	295	264	325
80	171	201	184
85	75	81	82

MAINTAINED ILLUMINATION TABLE- Square Feet/Fixture*

- 80-50-20 Reflectances (Ceiling-Wall-Floor)
- LLF = 0.75 2125 Lumens/Lamp very clean
- Room width divided by room height = 5 or more, 2 or 1

Fixture Size & # of Lamps	Room Width Room Height =	Approx. Area (sq. ft.) per Fixture				
		10 ft-c	30 ft-c	50 ft-c	70 ft-c	100 ft-c
3' X 3'	5	-	-	108	77	54
4 Lamp	2	-	127	76	55	38
	1	-	95	57	41	-

*Observe Fixture S/MH Requirements for Specific Applications

AVERAGE LUMINANCE CD/SQ.M WITH 2125 LUMEN LAMPS

ANGLE	END	45°	CROSS
45	3015	3631	4259
55	1943	1989	2478
65	1180	1453	1377
75	1528	1368	1684
85	1154	1246	1262

TYPICAL V.C.P.'s

Room Size	Mounting Height			
	Lengthwise	Crosswise	8.5	10
30x30	64	68	62	66
40x40	61	64	60	62
60x30	66	69	65	68
60x60	58	60	57	59
100x100	58	58	57	58

COEFFICIENT OF UTILIZATION

ptc pcc pw RCR	20				70				50			
	80	50	30	70	50	30	50	30	50	30	50	30
0	94	94	94	93	93	93	89	89	89	89	89	89
1	88	83	81	85	82	80	79	77	77	77	77	77
2	81	75	69	79	72	68	70	67	67	67	67	67
3	73	67	60	71	65	59	63	57	57	57	57	57
4	68	59	53	67	58	53	56	52	52	52	52	52
5	63	54	46	61	53	46	51	46	46	46	46	46
6	58	48	41	56	47	41	46	40	40	40	40	40
7	55	44	38	53	44	38	42	36	36	36	36	36
8	51	40	34	50	40	34	39	34	34	34	34	34
9	47	36	30	46	36	30	35	30	30	30	30	30
10	45	34	28	44	34	28	33	28	28	28	28	28

LIGHT DISTRIBUTION

DEGREES	LUMENS	% LAMP	% FIXTURE
0-30	2198	25.9	32.4
0-40	3681	43.3	54.3
0-60	5916	69.6	87.3
0-90	6779	79.8	100.0

LLF = .75 LLF = LIGHT LOSS FACTOR LLF = LDD X LLD X BF LDD = VERY CLEAN 0.94 CLEAN 0.90
LLD = 0.88 @ 40% RATED LAMP LIFE BF = 0.91 ELECTRONIC BALLAST & T8 LAMP (RELAMP AT 70% LAMP LIFE)

DIMENSIONS

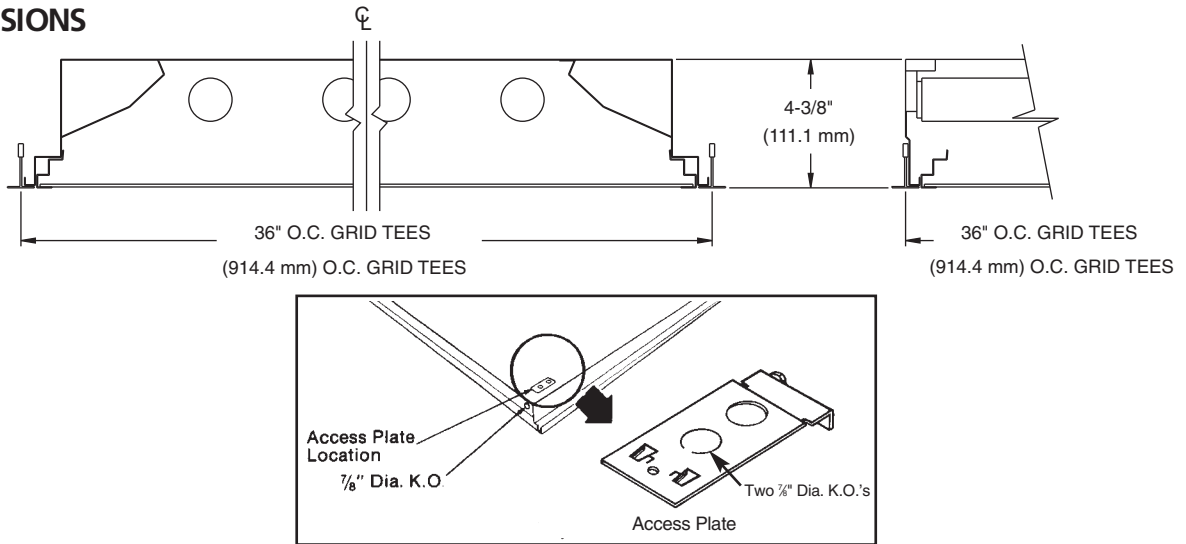

PHOTOMETRIC DATA

CATALOG # 3DG625-RA20-2/3-EB
TEST # 16156 S/MH=1.4

LAMPS = F25 T8
BALLAST = ELECTRONIC BALLAST FACTOR = .93

LER = FL-70

COMPARATIVE YEARLY LIGHTING ENERGY COST PER 1000 LUMENS = **\$3.43** BASED ON 3000 HRS. AND \$.08 PER KWH.

FIXTURE EFFICIENCY= 76.3%

CANDLEPOWER			
Angle	End	45	Cross
0	4028	4028	4028
5	4020	4009	4013
10	3963	3973	3997
15	3879	3921	3974
20	3753	3841	3939
25	3590	3748	3895
30	3391	3616	3832
35	3141	3450	3749
40	2818	3204	3601
45	2344	2703	3193
50	1720	1598	2221
55	1194	1184	1479
60	790	943	970
65	536	611	621
70	515	420	540
75	362	374	464
80	209	254	255
85	74	76	121

MAINTAINED ILLUMINATION TABLE- Square Feet/Fixture*

- 80-50-20 Reflectances (Ceiling-Wall-Floor)
- LLF = 0.77 2125 Lumens/Lamp very clean
- Room width divided by room height = 5 or more, 2 or 1

Fixture Size & # of Lamps	Room Width Room Height =	Approx. Area (sq. ft.) per Fixture				
		10 ft-c	30 ft-c	50 ft-c	70 ft-c	100 ft-c
3' X 3' 6 Lamp	5	-	-	-	113	79
	2	-	-	113	80	56
	1	-	140	84	60	42

*Observe Fixture S/MH Requirements for Specific Applications

AVERAGE LUMINANCE CD/SQ.M WITH 2125 LUMEN LAMPS			
ANGLE	END	45°	CROSS
45	4445	5126	6055
55	2791	2768	3457
65	1701	1939	1970
75	1875	1938	2404
85	1138	1169	1862

TYPICAL V.C.P.'s				
Room Size	Mounting Height			
	Lengthwise	Crosswise	8.5	10
30x30	57	61	54	58
40x40	54	57	52	54
60x30	59	62	57	61
60x60	52	53	49	51
100x100	53	53	49	50

COEFFICIENT OF UTILIZATION										
pfc pcc pw RCR	20			70			50			
	80	30	70	50	30	50	30	50	30	
0	91	91	91	89	89	89	84	84	84	
1	83	81	78	81	79	77	76	73	73	
2	77	71	67	75	69	66	68	64	64	
3	70	64	57	68	63	57	60	56	56	
4	66	56	51	64	56	51	55	50	50	
5	60	52	45	58	51	45	48	44	44	
6	56	46	40	55	46	40	45	40	40	
7	52	42	36	51	41	35	40	35	35	
8	48	39	33	47	39	33	38	32	32	
9	46	35	29	45	35	29	34	29	29	
10	42	33	28	41	33	27	32	27	27	

LIGHT DISTRIBUTION			
DEGREES	LUMENS	% LAMP	% FIXTURE
0-30	3217	25.2	33.1
0-40	5366	42.1	55.2
0-60	8531	66.9	87.7
0-90	9727	76.3	100.0

LLF = .77 LLF = LIGHT LOSS FACTOR LLF = LDD X LLD X BF LDD = VERY CLEAN 0.94 CLEAN 0.90
LLD = 0.88 @ 40% RATED LAMP LIFE BF = 0.93 ELECTRONIC BALLAST & F25 T8 LAMP (RELAMP AT 70% LAMP LIFE)

3' x 3'

3 D G 4 25

CEILING TYPE

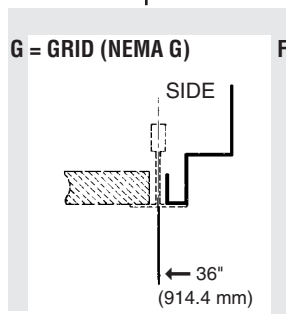

(NEMA Type G)
Lay-in acoustical ceilings
using exposed grid
suspension, with tees for
fixtures on 36" x 36" spacing.

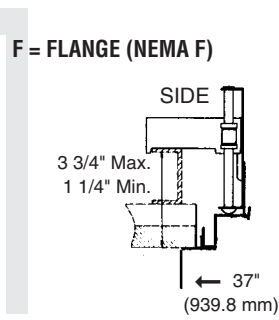

(NEMA Type F)
Flange for acoustical ceilings
using concealed mechanical
suspension. Swing-jack
mounting brackets: adjustment
3 3/4" max. and 1 1/4" min.