

Architectural Fluorescent

Surface Attune

2x4 2 Lamp T5, T5HO, or T8

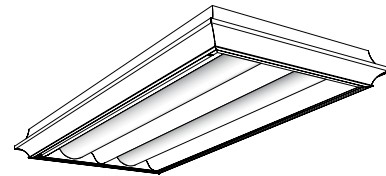

application

- Highly efficient, highly flexible surface mounted luminaire with an upscale architectural appearance.
- Modern, contoured shape provides architectural detail and a “floating” visual effect without dominating the room.
- Excellent visual comfort, ideal for modern high-tech offices.
- Other applications include schools and retail environments.
- Many ballast/lamp systems are available, providing flexibility to tailor the luminaire to specific applications.
- Standard distribution works well for conventional applications, while the wide “batwing” distribution allows wider luminaire spacing and improves uniformity for more even lighting.
- High optical efficiency increases energy savings.
- Step dimming ballasts can be switched to less than 50% input power for energy savings to meet most energy codes while maintaining symmetrical illumination.
- Multiple shielding options create a wide variety of photometric variations and aesthetic effects.

construction/finish

- Extruded aluminum external construction provides accurate, high quality fit and finish.
- Wireway cover is easily removable without tools for quick ballast or wiring access from below.
- Matte white external finish is standard, custom colors available.
- Approximate weight 48lbs.

electrical

- UL listed for damp locations. Canadian certified optional.
- Standard size fluorescent emergency ballasts can be incorporated, UL listed for dry locations.
- Systems are available offering electrical system efficacy ratings up to 102 Lumens/Watt.

enclosure

- One-piece enclosure hinges down as an assembly for easy access to lamps and ballast from below.
- T-hinges provide secure retention of enclosure and eliminate non-captive parts to hold during servicing.
- Guide-post spring loaded latches allow easy opening and closing of the enclosure.
- Choice of shielding includes diffuse acrylic with or without overlay, white radial louver with overlay, round or linear perforated steel with overlay.

Specifier's Reference

Project
Type
Model No.
Comments

Green Choice: 2SATN232-D-UNV-1/2-EBLHE-LPT835HL

2	SAT	2	-	-	1/2	-	-
Family SAT – Surface Attune	No. of Lamps (not included) 2	Diffusers D – Diffuse DO – Diffuse w/overlay WO – White Radial Louver w/overlay PMW – Round Perf. w/white overlay SMW – Slotted (Linear) Perf. w/white overlay			Ballast 1/2 – One 2-Lamp ballast	Options CM – Canadian Market CC – Custom Color E1* – DEB-1 emerg. ballast, T8 lamps, 350-450 lumens E7* – DEB-7 emerg. ballast, T8 lamps, 600-700 lumens E5* – DEB-5 emerg. ballast, T8 lamps, 1100-1400 lumens E7LP* – DEB-7LP emerg. ballast T5/T5HO, 430-700 lumens E6LP* – DEB-6LP emerg. ballast, T5/T5HO lamps, 750-1325 lumens GLR# – Fusing, fast blow (# = number of ballasts) LPT730 – Installed T8 lamps, 70+ CRI, 3000K LPT735 – Installed T8 lamps, 70+ CRI, 3500K LPT741 – Installed T8 lamps, 70+ CRI, 4100K LPT830HL – Installed T8 hi lumen lamps, 80+ CRI, 3000K LPT835HL – Installed T8 hi lumen lamps, 80+ CRI, 3500K LPT841HL – Installed T8 hi lumen lamps, 80+ CRI, 4100K LPT830 – Installed T8/T5/T5HO lamps, 80+ CRI, 3000K LPT835 – Installed T8/T5/T5HO lamps, 80+ CRI, 3500K LPT841 – Installed T8/T5/T5HO lamps, 80+ CRI, 4100K *Factory installed	
Width 2 – 2'	Distribution N – Standard W – Wide (Batwing)	Lamp Type/ Wattage 28 – 28WT5 (46") 32 – 32WT8 (48") 54HO – 54WT5HO (46")	Voltage 120 277 347 UNV – Universal Voltage, 120-277 volt			Ballast Type EB95 – 28WT5 Electronic ballast, .95 ballast factor EB115 – 28WT5 Electronic ballast, 1.15 ballast factor EBSD95 – 28WT5 Electronic step dimming ballast, .95 ballast factor EBSD115 – 28WT5 Electronic step dimming ballast, 1.15 ballast factor EBSD80 – 54WT5HO Electronic step dimming ballast, .80 ballast factor EBD – T5/T5HO/T8 electronic dimming ballast EB – T5/T5HO/T8 electronic ballast, std. ballast factor EBL – T8 Electronic ballast, low ballast factor EBH – T8 Electronic ballast, hi ballast factor EB101 – T8 Electronic ballast, <10% THD, instant start EB10R – T8 Electronic ballast, <10% THD, rapid start EBSD – T8 Electronic step dimming ballast EBHE – T8 electronic ballast, high efficiency, std. ballast factor EBLHE – T8 electronic ballast, high efficiency, low ballast factor EBHHE – T8 electronic ballast, high efficiency, high ballast factor	

energy data

Lamp Type	Ballast Type	Input Power (120/277V)	Electrical System Lumens/Watt	
			Std. Lamps*	Hi-Lumen Lamps
28	EB95	59W / 58W	95	100
	EBS95@hi	59W / 58W	95	100
	EBS95@lo	28W / 28W	73	76
	EB115	71W / 69W	97	102
	EBS115@hi	71W / 71W	94	99
	EBS115@lo	35W / 35W	80	81
	EB	66W / 64W	91	95
32	EB	58W / 58W	85	94
	EBHE	55W / 54W	90	100
	EB10I	59W / 58W	85	94
	EB10R	62W / 60W	82	91
	EBL	50W / 49W	88	97
	EBLHE	47W / 47W	92	102
	EBH	77W / 77W	87	97
	EBHHE	74W / 73W	91	100
	EBS@hi	57W / 56W	88	97
	EBS@lo	28W / 28W	60	66
	54HO	EB	120W / 117W	85
EBS80@hi		96W / 93W	86	-
EBS80@lo		52W / 51W	78	-

*Standard lamp T8 values assume 70+CRI 32W lamp. 80+CRI lamps or energy saving lamps are also available.

dimensions

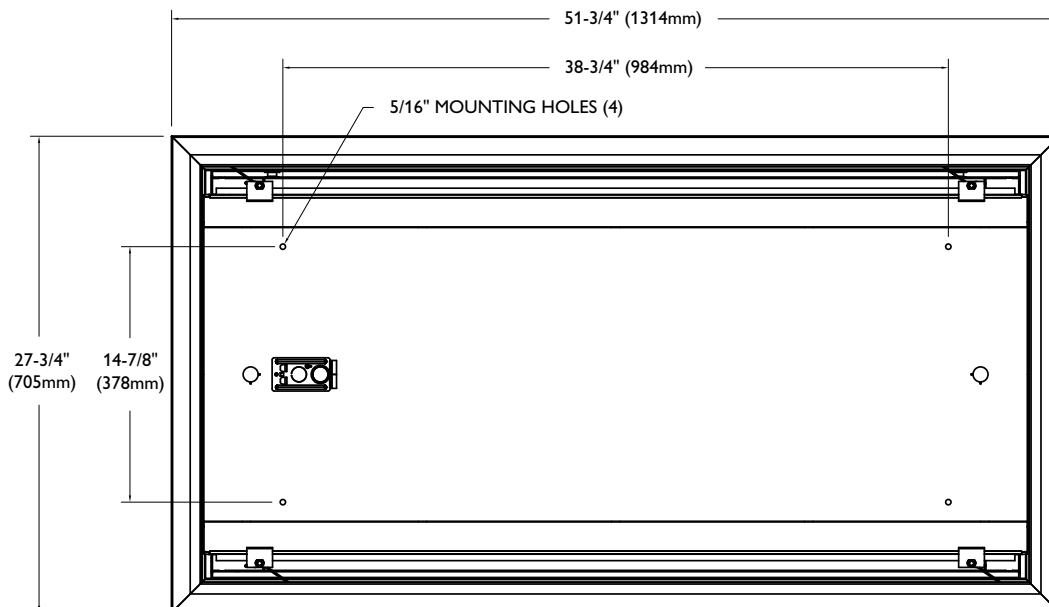
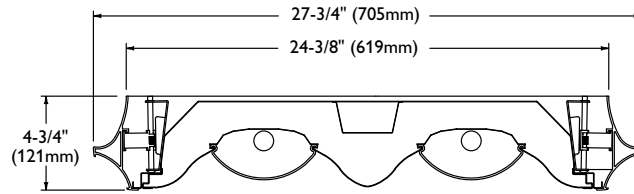

photometry

SAT 2x4 2 Lamp T5 Wide Diffuse

Efficiency – 90.2%

LER – 70

TER – 61

Catalog No. 2SATW228-D-1/2-EB Test No. 25469D2 S/MH 1.5 Lamp Type F28T5 Lumens/Lamp 2600 Ballast Factor 1.00 Input Watts 67 Comparative yearly lighting energy cost per 1000 lumens – \$3.43 based on 3000 hrs. and \$.08 pwr KWH. The photometric results were obtained in the Philips Day-Brite laboratory which is NVLAP accredited by the National Institute of Standards and Technology.	Candlepower				Light Distribution			
	Angle	End	45	Cross	Degrees	Lumens	% Lamp	% Luminaire
	0	1510	1510	1510	0-30	1304	25.1	27.8
	5	1520	1522	1515	0-40	2184	42.0	46.6
	10	1501	1543	1579	0-60	3840	73.9	81.9
	15	1467	1569	1649	0-90	4691	90.2	100.0
	20	1422	1584	1699				
	25	1362	1577	1699				
	30	1288	1540	1639				
	35	1200	1459	1527				
	40	1095	1348	1378				
45	982	1210	1218					
50	854	1057	1059					
55	726	897	901					
60	594	747	737					
65	467	590	551					
70	342	428	348					
75	230	263	185					
80	131	128	85					
85	51	35	21					

SAT 2x4 2 Lamp T5 Standard Diffuse

Efficiency – 85.0%

LER – 70

TER – 63

Catalog No. 2SATN228-D-1/2-EB Test No. 25459D2 S/MH 1.2 Lamp Type F28T5 Lumens/Lamp 2600 Ballast Factor 1.00 Input Watts 63 Comparative yearly lighting energy cost per 1000 lumens – \$3.43 based on 3000 hrs. and \$.08 pwr KWH. The photometric results were obtained in the Philips Day-Brite laboratory which is NVLAP accredited by the National Institute of Standards and Technology.	Candlepower				Light Distribution			
	Angle	End	45	Cross	Degrees	Lumens	% Lamp	% Luminaire
	0	1941	1941	1941	0-30	1465	28.2	33.2
	5	1936	1936	1901	0-40	2332	44.8	52.8
	10	1901	1901	1868	0-60	3795	73.0	85.9
	15	1846	1845	1814	0-90	4417	85.0	100.0
	20	1763	1768	1738				
	25	1663	1666	1630				
	30	1538	1542	1504				
	35	1401	1398	1356				
	40	1242	1246	1187				
45	1077	1080	1009					
50	911	914	834					
55	748	748	637					
60	594	595	430					
65	451	430	283					
70	323	283	185					
75	211	170	118					
80	116	88	65					
85	46	29	19					

SAT 2x4 2 Lamp T8 Wide Diffuse

Efficiency – 84.3%

LER – 72

TER – 62

Catalog No. 2SATW232-D-1/2-EB Test No. 25445D2 S/MH 1.5 Lamp Type F32T8 Lumens/Lamp 2850 Ballast Factor .88 Input Watts 59 Comparative yearly lighting energy cost per 1000 lumens – \$3.33 based on 3000 hrs. and \$.08 pwr KWH. The photometric results were obtained in the Philips Day-Brite laboratory which is NVLAP accredited by the National Institute of Standards and Technology.	Candlepower				Light Distribution			
	Angle	End	45	Cross	Degrees	Lumens	% Lamp	% Luminaire
	0	1524	1524	1524	0-30	1279	22.4	26.6
	5	1535	1529	1518	0-40	2161	37.9	45.0
	10	1515	1535	1551	0-60	3933	69.0	81.8
	15	1480	1540	1590	0-90	4806	84.3	100.0
	20	1433	1538	1621				
	25	1372	1522	1633				
	30	1300	1492	1624				
	35	1210	1433	1568				
	40	1102	1352	1487				
45	990	1251	1378					
50	865	1127	1236					
55	738	990	1038					
60	606	838	779					
65	477	644	526					
70	352	438	319					
75	238	255	175					
80	138	122	83					
85	54	34	22					

SAT 2x4 2 Lamp T8 Standard Diffuse Efficiency – 88.0%

LER – 74

TER – 66

Catalog No. 2SATN232-D-1/2-EB Test No. 25418D2 S/MH 1.2 Lamp Type F32T8 Lumens/Lamp 2850 Ballast Factor .88 Input Watts 60 Comparative yearly lighting energy cost per 1000 lumens – \$3.24 based on 3000 hrs. and \$.08 pwr KWH. The photometric results were obtained in the Philips Day-Brite laboratory which is NVLAP accredited by the National Institute of Standards and Technology.	Candlepower				Light Distribution								
	Angle	End	45	Cross	Degrees	Lumens	% Lamp	% Luminaire					
	0	2052	2052	2052	0-30	1576	27.6	31.4					
	5	2063	2042	2028	0-40	2539	44.5	50.6					
	10	2026	2015	2005	0-60	4243	74.4	84.6					
	15	1966	1964	1963	0-90	5017	88.0	100.0					
	20	1886	1897	1900	Coefficients of Utilization								
	25	1783	1803	1810	EFFECTIVE FLOOR CAVITY REFLECTANCE 20 PER (pfc=0.20)								
	30	1651	1688	1696	pcc	80		70		50			
	35	1512	1560	1561	pw	70	50	30	70	50	30	50	30
	40	1353	1398	1396	RCR								
45	1179	1231	1226	0	105	105	105	102	102	102	97	97	
50	1005	1060	1045	1	96	93	89	93	91	88	86	84	
55	833	891	827	2	89	81	76	85	80	75	77	72	
60	666	722	595	3	81	71	66	79	70	65	68	63	
65	511	540	396	4	75	65	56	72	63	56	60	55	
70	368	362	254	5	68	57	50	67	56	50	55	48	
75	242	219	159	6	64	52	45	61	52	44	50	44	
80	137	117	86	7	58	47	40	57	46	40	46	39	
85	54	37	24	8	55	44	35	54	42	35	41	35	
				9	52	40	33	50	40	33	39	32	
				10	47	36	29	46	36	29	35	29	

SAT 2x4 2 Lamp T8 Radial Louver Efficiency – 69.7%

Efficiency – 69.7%

LER – 59

TER – 52

Catalog No. 2SATW232-WO-1/2-EB Test No. 25793D2 S/MH 1.3 Lamp Type F32T8 Lumens/Lamp 2850 Ballast Factor .88 Input Watts 59 Comparative yearly lighting energy cost per 1000 lumens – \$4.07 based on 3000 hrs. and \$.08 pwr KWH. The photometric results were obtained in the Philips Day-Brite laboratory which is NVLAP accredited by the National Institute of Standards and Technology.	Candlepower				Light Distribution							
	Angle	End	45	Cross	Degrees	Lumens	% Lamp	% Luminaire				
	0	1695	1695	1695	0-30	1260	22.1	31.7				
	5	1683	1678	1676	0-40	2011	35.3	50.6				
	10	1609	1635	1674	0-60	3330	58.4	83.8				
	15	1520	1575	1666	0-90	3972	69.7	100.0				
	20	1415	1503	1644	Coefficients of Utilization							
	25	1286	1410	1586	EFFECTIVE FLOOR CAVITY REFLECTANCE 20 PER (pfc=0.20)							
	30	1174	1319	1504	pcc	80		70		50		
	35	1034	1195	1404	pw	70	50	30	70	50	30	
	40	890	1064	1288	RCR							
45	742	927	1163	0	82	82	82	81	81	81	77	77
50	592	790	1041	1	76	72	70	75	71	68	68	67
55	437	669	906	2	69	65	59	68	63	58	60	57
60	299	554	760	3	64	56	52	61	56	51	54	50
65	225	454	551	4	58	51	45	56	50	45	47	44
70	169	340	340	5	54	46	40	53	45	39	44	39
75	121	216	130	6	50	40	35	48	40	34	40	34
80	75	109	31	7	46	38	32	46	36	32	35	30
85	32	47	11	8	44	34	28	42	34	28	33	28
				9	40	32	26	40	30	26	30	26
				10	38	28	23	36	28	23	28	23



©2011 Philips Day-Brite
All rights reserved.

776 South Green Street • Tupelo, MS 38804
p. 800.234.1890 • f. 662.841.5501
Canadian Division
189 Bullock Drive • Markham, Ontario L3P 1W4
p. 905.294.9570 • f. 905.294.9811

Contact Factory for Additional Configurations.

Specifications are subject to change without notice.

Some luminaires use fluorescent or high intensity discharge (HID) lamps that contain small amounts of mercury. Such lamps are labeled, "Contain Mercury" and/or the symbol "HG". Lamps that contain mercury must be disposed of in accordance with local requirements. Information regarding lamp recycling and disposal can be found at www.lamprecycle.org

