

SUBJECT:

APEX LOW BAY "APL" SERIES

Day-Brite Lighting INSTRUCTION SHEET

WARNING: ELECTRICAL SHOCK POTENTIAL !! DO NOT ATTEMPT TO INSTALL, MAINTAIN OR RELAMP WITHOUT DISCONNECTING ALL POWER. FAILURE TO DISCONNECT POWER CAN RESULT IN ELECTROCUTION, SHOCK OR SEVERE BURNS.

CAUTION: This fixture is designed for permanent installation in ordinary (Non-Hazardous) locations in accordance with the National Electrical Code and all applicable local codes. Do not use in areas of limited ventilation or in high ambient enclosures. The lamp and fixture operate at high temperatures, contact with combustible materials can cause fire and personal contact can cause severe burns.

MOUNTING UNIT TO CONDUIT

LOCATE MOUNTING NUT & HUB IN CARTON.

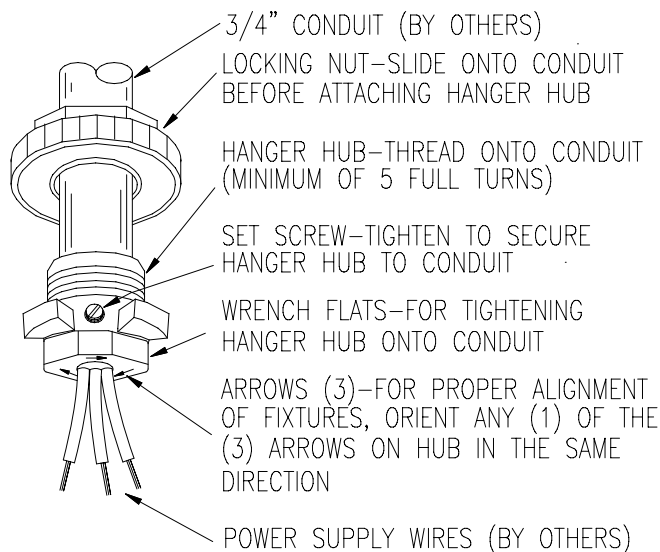

- 1) LIFT ENTIRE UNIT ONTO THE HANGER HUB AND ROTATE 60° UNTIL SEATED ON HUB
- 2) TURN LOCKING NUT (HAND TIGHT) ONTO HANGER HUB TO SECURE UNIT

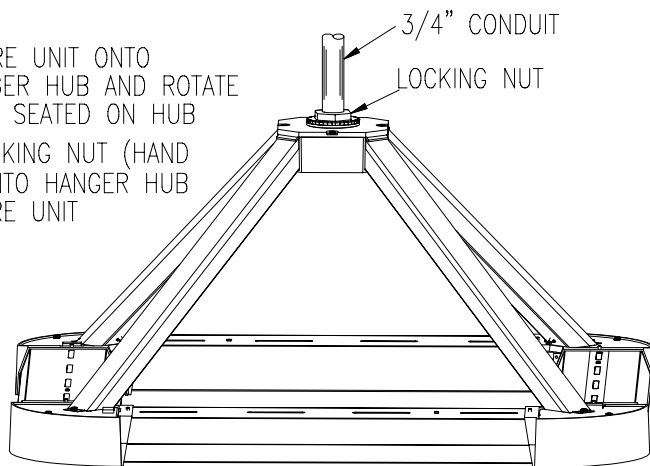

WARNING: LOCKING NUT MUST ENGAGE THREADS ON HANGER HUB AND BE HAND TIGHTENED TO INSURE THAT FIXTURE IS PROPERLY SEATED ON HUB

CAUTION: THE LOCKING NUT IS PROVIDED WITH WRENCH FLATS TO BE USED ONLY IF NECESSARY TO REMOVE NUT

WIRING & LAMPING

- 1) LOOSEN (DO NOT REMOVE) THE (2) #6 SCREWS UNDER THE MOUNTING/WIRING BOX AND ROTATE THE WIRING COVER OPEN

- 2) PULL FIXTURE LEADS AND SUPPLY LEADS OUTSIDE THE WIRING BOX. MAKE SUPPLY CONNECTIONS IN ACCORDANCE WITH ALL APPLICABLE ELECTRICAL CODES.

NOTE: LUMINAIRE MUST BE GROUNDED.

- 3) PUSH ALL LEADS BACK INTO WIRING BOX AND REPLACE ACCESS PLATE. SECURE BY TIGHTENING #6 SCREWS.

- 4) REMOVE PROTECTIVE FILM FROM ALL REFLECTORS.

- 5) INSTALL LAMPS. INSURE THAT LAMPS ARE INSERTED INTO LAMP CLIPS.

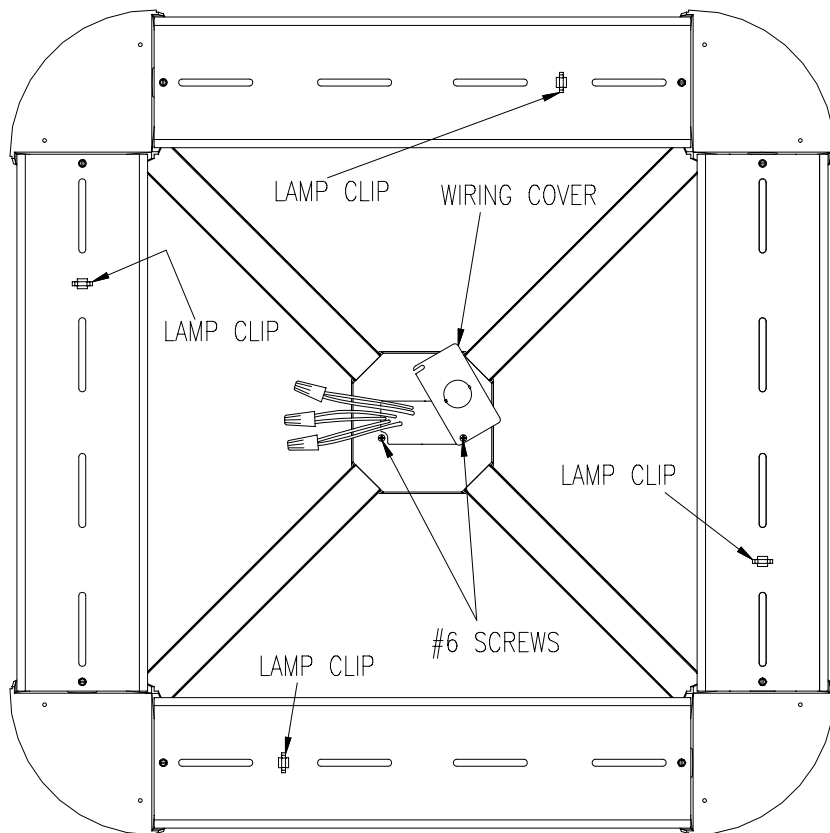

PART NO. 7-87625-883 (FRONT) May, 2005